

## Smart Wheelchair Based on Eye Tracking and ECG Monitoring System for Assistive Mobility and Continuous Patient Health Assessment

Dr. Sophie Tremblay<sup>1\*</sup>

<sup>1</sup>McGill University Faculty of Medicine, Department of Biomedical Engineering and Rehabilitation Medicine, Montreal, Canada

### ABSTRACT

This project is a smart wheelchair based on eye tracking and ECG measuring system which is designed for people with locomotor disabilities. This eye controlled wheelchair[3] eliminates the assistance required for the disabled person. In this system, controlling of wheelchair is depend on eye movements and ECG measuring system measures the ECG of a patient[8] on wheelchair moving or pausing and transmit measured signals to a remote server through CDMA. The smart wheel chair consists of five modules including imaging processing module, wheelchair-controlled module, ECG measuring module, SMS manager module and appliance-controlled module. The image processing module consists of a webcam installed on the eyeglass and C++ customized image processing software. The captured image will be transmitted to raspberry Pi microcontroller which will be processed using OpenCV to derive the 2D direction of eye ball. The coordinate of eyeball movement is wirelessly transmitted to wheelchair-controlled module to control the movement of wheel chair. The wheelchair-controlled module has two dimensional rotating stages that is installed to the joystick of the electrical wheelchair to replace the manual control of the wheelchair. In order to acquire ECG, the system has an amplifier for each signal, and records the signals on a SD card through an A/D converter. The data which recorded in the SD card is transmitted to a remote server using a CDMA module. In conclusion, this project develops a system that is based on eye tracking and ECG measurements[8] from patients on wheelchair.

**KEYWORDS:** ECG, CDMA, Raspberry pi microcontroller.

---

### 1. INTRODUCTION

Presently, wheelchairs have become important for elderly and disabled persons. The electrical wheelchairs available in market are mostly controlled by a joystick control system. In some cases such as totally paralysis person in amyotrophic Lateral Sclerosis (ALS) and Parkinson disease, it may be very difficult or impossible for such patient to use such type of system. Some researchers have an attempt to develop other techniques for controlling electrical wheelchair and they aim to improve quality of life of the patient. Such attempts are voice control system, brain control system and eye control system. In the case of voice controlled wheelchair[5], patients speak to the command system and it works such as forward, right, left, and stop and the system will recognize the word and send command to move the wheelchair. The drawback of voice controlled wheelchair is the low immunity to noisy environment that can distract the system and it also causes the system to respond incorrectly. For brain controlled wheelchair, by using the EEG signal[6], patient could easily command but the setup method is somewhat inconvenient.

This project aims to develop a prototype of a smart wheelchair that is controlled with eye movement. Eye tracking wheelchair[2] is to enable completely paralyzed patient as well as elderly to make their life more accessible. Infrared reflection based on eye pupil detection system provides accurate detection of eye pupil centre location. But the infrared radiation affects the eye and people may loss the eye visibility. Eye tracking wheelchair system is introduced using camera for capturing the image. Camera captures the image based on face, eye and eye pupil detection with minimum delay of time and analyse the image as input to set the commands to interface the motor driver IC through sending the command to GPIO pins[1], in order to perform the different operation such as left, right, forward and stop. Image processing based on open computer vision library is used for face and eye detection. System includes multistage that is to track the eye pupil centre. Detecting the single or multiple face and detection of both eyes is the ultimate goal of this system.

ECG is the most common method for evaluating and recording cardiac cycles and functions. Using the system, we expect to acquire ECG signal[8] that is an electric signal generated by heart beat and detected on body surface. Recently, biomedical sensors are under development using wireless technologies such as Zigbee[9] in order to transmit biosignals such as ECG. In case an event has happened on the equipment (the button on the equipment is pressed, the heart rate of ECG signal is below 40 or above 180, or the ECG lead falls off), the data of the patient on the wheelchair is transmitted to a remote server through CDMA network, and the latest 48Kbyte data until the moment of the event (around 32 seconds before the event) are stored and recorded. The

reason that 48 Kbyte data are transmitted is that 30 seconds' data are considered enough to determine the patient's state just before the event.

## 2. SYSTEM ARCHITECTURE

### Eye tracking

The system starts with web camera to capture the eye images and send signal to Raspberry Pi for digital image processing which is based on OpenCV library to derive the 2D motion direction of eyeball. The motion direction of eyeball is also used as the cursor control on the raspberry Pi screen to control some operation such as wheelchair control. Image processing includes face detection, eye detection, color image to gray conversion, blurring, edge detection, pattern matching, filtering, noise reduction[5].

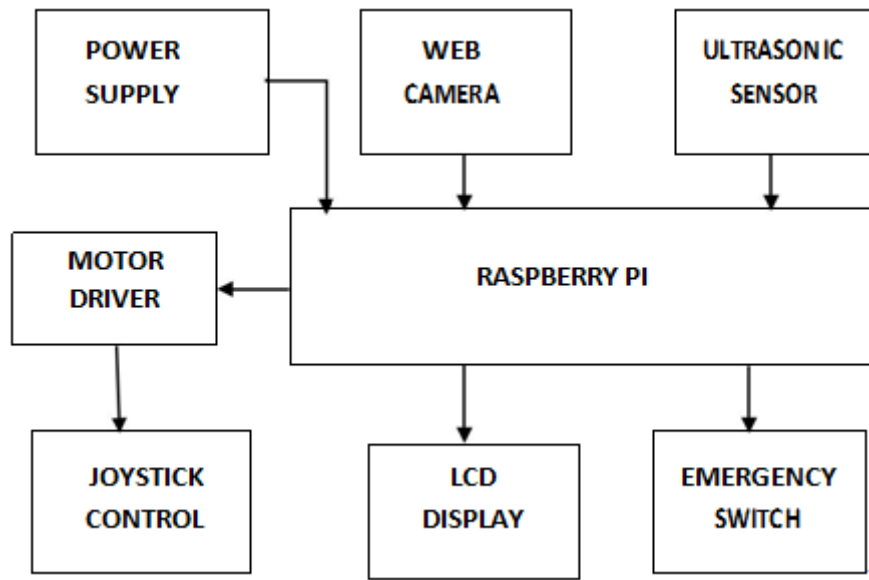

System architecture – Eye tracking

Raspberry pi board is the soul of the system, which controls the complete system operation. Image processing based on data signal is sent to the raspberry pi board, then raspberry pi receives the data and analyse it and then send the control signal to motor driving circuit, which is based on the location of eye pupil. This will decide whether to run motor either in clockwise or anticlockwise direction or stop. Two individual motors are mounted on each wheel. Ultrasonic sensor[4] is introduced on the wheelchair for obstacle detection. If the sensor gets any obstacle very close to the wheelchair, it indicates to the raspberry pi board and it will sends the signal to motor which is driving the circuit to stop it.

### A. HARDWARE DESCRIPTION

#### 1) Raspberry pi board

Raspberry pi board is the brain of the system. Raspberry pi board has its own operating system, known as raspbian which is Linux based operating system and compatible with raspberry pi board. A real time data is received and determines the digital data by raspberry pi B+ model board, which very efficiently work with the multiple images. Raspberry pi sends the command to the motor driver which is enabling the GPIO pin[1] to raspberry pi.

#### 2) Web camera

Webcam is used for capturing the image. We can use HD camera but it increases the memory size and the system is not able to read the image and it will increase the processing time. UV4L driver is used for interfacing a camera with raspberry pi board.

#### 3) Ultrasonic sensor

Ultrasonic sensor[4] is used to detect the presence obstacle in the path of wheelchair. It is directly connected to the raspberry pi board. It receives the data and measures the distance between wheelchair and obstacle. If any

object is detected very close to wheelchair, motors will stop to run the wheels. Ultrasonic sensor is a distance sensor that has been used mainly for object avoidance in various robotics projects.

#### 4) Motor

Two 12V DC motors are used in this project to demonstrate running of wheelchair in forward, reverse, left and right direction. L293D motor driver is used to interface with raspberry pi board which is TTL compatible. Two H bridges of L293D are connected in parallel to increase its current capacity to 2 Amp.

#### 5) LCD (Liquid crystal display)

LCD is used as user interface as well as for debugging purpose. The most common LCD controller is HITACHI 44780 which provides a simple interface between the controller and LCD. LCD is used as a monitor in most of the project.

#### 6) Relay

Relay is an electromechanical device. It basically consists of an electromagnet and a number of contact sets. Relay is used in this system to order to change the direction of motor very fast without using the finger.

### B) SOFTWARE DESCRIPTION

#### 1) Putty software

Putty software is a free and open source terminal emulator and network file transfer application. It is used to connect the desktop to raspberry pi board.

#### 2) OpenCV image library

OpenCV is released under a BSD license. It is free for academic as well as commercial use. It has C++, C, Python and Java interfaces and supports Windows, Linux, Mac OS, and Android. It was designed for computational efficiency and with a strong focus on real time application.

#### 3) Python language

Python is an object oriented, interpreter and high level programming language. Its high level built in data structures, combined with dynamic typing as well as dynamic binding which make it very attractive for rapid application development. Python is easy to learn and therefore reduce the cost of program maintenance. The fast edit – test– debug cycle makes it very effective. Matlab is used for coding. But it is quite expensive. Math work puts restriction on code portability.

### ECG measuring system

ECG signal is passed through amplifier and it goes through A/D conversion at MCU, and 3-axis acceleration signal goes through A/D conversion without amplification[8]. Signal input to MCU is digitalized and recorded in the SD card with FAT32 format, and on the happening of an event, transmitted to a remote server through CDMA network. The sampling rate of ECG lead I, II and BCG is 200 Hz, and the sampling rate of the 3-axis acceleration sensor is 20 Hz.

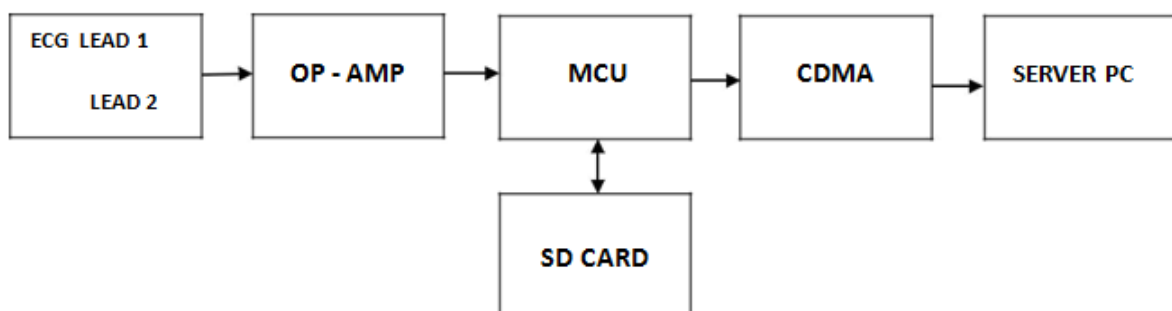

*System architecture – ECG measuring system*

## 3. DESIGN METHODS

### Eye tracking

Several stages used to determine eye movement such as face and eye detection[7], colour to gray conversion, canny edge detection, and eye tracking. Initially the system received the captured images using USB web camera. For the face and eye detection Haar cascade algorithm has been used. After detection of face, it will try

to detect the eye inside the face draw the rectangular box over the eye. To detect the eye pupil and define its centre points is its ultimate goal of the system by several images processing technique.

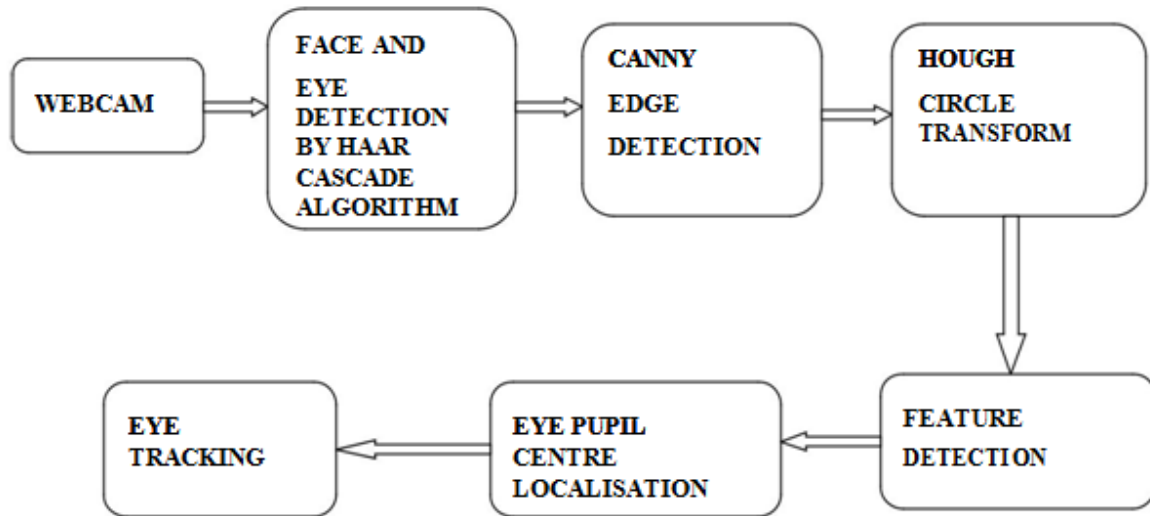

*Proposed method*

If any obstacle is detected, the system will be stopped and moved either in left or right direction according to eye movement. If someone calls the user, then the user will stop the wheelchair by emergency switch. Eye blinking[2] logic will decide the start and stop operation. For circle detection Hough circle transform method has been used. Image processing based on openCV library has been installed in raspberry pi memory. To track the eye movement we are using coordinate system which decide the eye centre point location. Here A1 and A2 is corner point of eye pupil in X direction, B1 and B2 is corner point of eye pupil in Y direction. The X and Y calibration point represents the direction of the eye movements. The eyeball position at the (A0, B0) points will be:  $A0 = (A1+A2) / 2$ ,  $B0 = (B1+B2)$

### ECG Measuring System

ECG circuit[8] was also built with a low price operational amplifier (TL064,TI) as an instrumentation amplifier suitable for low-power system. In order to get the patient's ECG signal, we need four electrodes. Three of them has been used for standard induction VI, VI, and VIII, and one for attenuating noises and stabilizing signals. Input signal is amplified by the 2-channel ECG amplifier, and 60Hz noises are attenuated with the help of a notch filter.

The polarity of filtered signal is inverted by an inverting amplifier, and the inverted signal passes through a low pass filter (LPF 79.577 Hz). Again the signal passes through a high pass filter (HPF 0.169 Hz) which is supplied to the A/D port of the micro-controller.

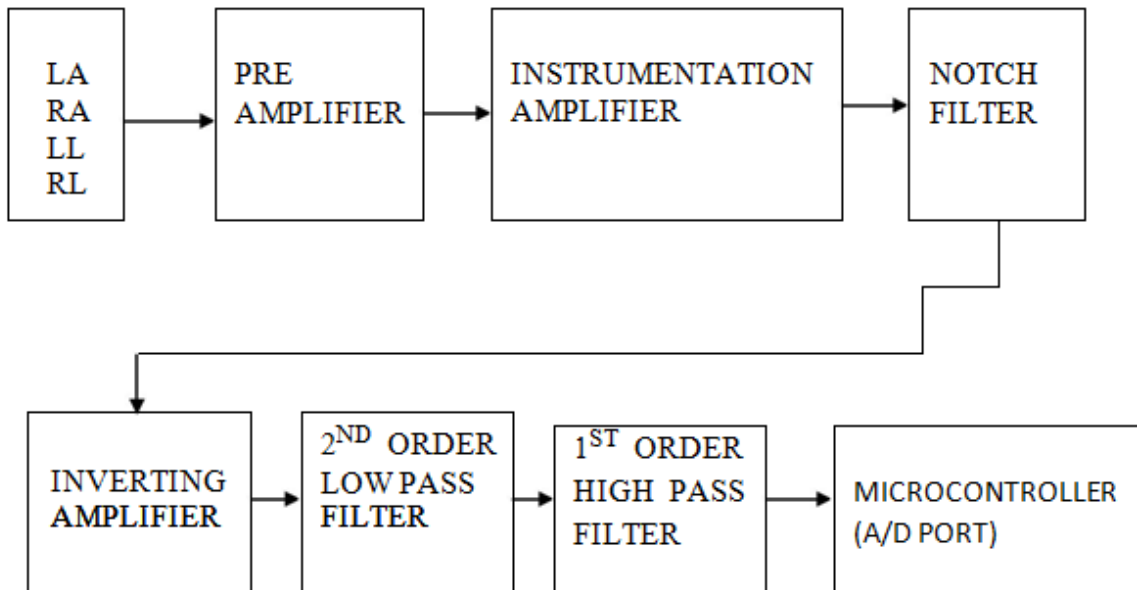

Block diagram of 2-channel ECG circuit

#### 4. IMPLEMENTATION AND SYSTEM DESCRIPTION

The low power consumption credit card sized raspberry pi B+ board has been used, which have inbuilt 40 pin GPIO[1], 4 USB ports, UART, PWM, HDMI port and Ethernet adapter port for internet connection through wireless or wired connection. Raspberry pi have a 512 MB RAM and capable of up to 32 GB external memory, based on ARM architecture. Camera is directly connected with raspberry pi board and it continuously captures the images, distance between eye and camera device is fixed. It may be from 10 to 15 cm.

Face and eye[3] detected by Haar cascade algorithm, find out the exact pupil location. Then several algorithms are used to measure the centre point from the average of both corners of the eye. This gives the correct information about eye movements. The motor driving circuit is connected with raspberry, battery for power supply of motors and relay for controlling the motor driving IC. System continuously generates the directive signal in order to enable the GPIO pins and perform the required operation like left, right, forward and stop. Central switch is also connected with system if there is any emergency purpose. Ultrasonic sensor[4] are used for obstacle detection.

#### 5. SYSTEM INSTALLATION

To boot a train image in micro SD card win32 diskimager software has been used. Then putting a bootable memory device on raspberry pi board and hence admit the raspbian operating system directly without resetting.

#### 6. CONCLUSION

In this project we develop a wheelchair system along with an ECG measuring system which enables the disabled or paralyzed patient to move their wheelchair independently in their own direction. An ECG measuring system measures the ECG of the patient and transmit measured signals to a remote server through CDMA network. In real time application, we can use camera, emergency switch and ultrasonic sensor depending on their application. The wheelchair movement operation with some delay time. Dark light places affect the performance of wheelchair, which is difficult to track the eye pupil in dark light.

#### REFERENCES

- [1] Sarangi, P., Grassi, V., Kumar, V., Okamoto, J.: Integrating Human Input with autonomous behaviours on an Intelligent Wheelchair Platform, Journal of IEEE Intelligent System, 22, 2, 33-41, [2007].
- [2] Matt Bailey, ET. Al, —Development of Vision Based Navigation for a Robotic Wheelchair, in
- [3] Shafi. M, Chung. P. W. H.: A Hybrid Method for Eyes Detection in Facial Images, International Journal of Electrical, Computer, and Systems Engineering, 231-236, [2009].
- [4] Automation of wheelchair using ultrasonic and body kinematics, Preethika Britto, Indumathi. J, Sudesh Sivasasu, Lazar Mathew, CSIO Chandigarh, INDIA, 19-20 March 2010.

- [5] Romil Chauhan, Yash Jain, Harsh Agarwal and Abhijit Patil, "Study of Implementation of Voice Controlled Wheelchair," 2016 3rd International Conference on Advanced Computing and Communication Systems (ICACCS-2016), 2016.
- [6] Abhilash Kodi, Dixit Kumar, Divya Kodali and I.A.Pasha, "EEG – Controlled Wheelchair for ALS patients," 2013 International Conference on Communication Systems and Network Technologies, 2013.
- [7] K. Arai, R. Mardiyanto, "Eyes Based Electric Wheel Chair Control System," International Journal of Advanced Computer Science and Application (IJACSA), Vol. 2, No. 12, 2011. K.Arai, R. Mardiyanto, "Eyes Based Electric Wheel Chair Control System," International Journal of Advanced Computer Science and Application (IJACSA), Vol. 2, No. 12, 2011.
- [8] J. M. Kim, J. H. Hong, N. J. Kim, E. J. Cha, T. S. Lee, "Two algorithms for detecting respiratory rate from ECG signal," World Congress on Medical Physics and Biomedical Engineering, pp. 54, 2006.
- [9] J. H. Hong, N. J. Kim, E. J. Cha, T. S. Lee, "Zigbee based Photoplethysmography", Journal of Korea Intellectual Patent Society, vol.8, no. 3, pp.31 -35, Sep. 2006.
- [10] Y. G. Lim, K. H. Hong, K. K. Kim, J. H. Shin, K. S. Park, "Mechanocardiogram measured at the back of subjects sitting in a chair as a non-intrusive pre-ejection period measurement," Pervasive Health Conference and Workshops, pp. 1-4, Nov. 2006.